

GRANCO FLOW CHART (50-100 PSI/VISCOSITIES 32-1000 SSU)

TRUCK-MOUNTED PUMPS

<u>Model</u>	<u>300 RPM</u>	<u>500 RPM</u>	<u>600 RPM</u>	<u>750 RPM</u>	<u>1000 RPM</u>
DDM/DDM-H	36 GPM	60 GPM	N/A	N/A	N/A
DEEM/DEEM-H	36 GPM	60 GPM	72 GPM	90 GPM	N/A
EEM/EEM-H	60 GPM	100 GPM	120 GPM	N/A	N/A
ELM/ELM-H	60 GPM	100 GPM	120 GPM	150 GPM	N/A
HHM/HHM-H	150 GPM	200 GPM	300 GPM	375 GPM	400 GPM

GRANCO FLOW CHART (50-100 PSI/VISCOSITIES TO 10,000 SSU)

DDM/DDM/H 28 GPM

DEEM/DEEM-H	28 GPM	48 GPM @ 380 RPM
EEM/EEM-H	60 GPM	70 GPM @ 350 RPM
ELM/ELM-H	60 GPM	80 GPM @ 400 RPM
HHM-HHM-H		150 GPM @ 300 RPM

NOTES: THESE FIGURES REPRESENT THE MAXIMUM FLOW RATE AT 50-100 PSI WITHOUT THE PUMP CAVITATING DUE TO THE HIGH VISCOSITY. HOWEVER, FOR EXAMPLE, THE HHM PUMP CAN STILL MOVE A MAXIMUM OF 70 GPM OF FLUID OVER 100,000 SSU AT A SPEED OF 160 RPM. THIS CHART ASSUMES A 3 OR 4" DISCHARGE PIPE.

*Pressures are 50-100 PSI

*Viscosity 30-1000 SSU

GRANCO SELECTION CHARTS

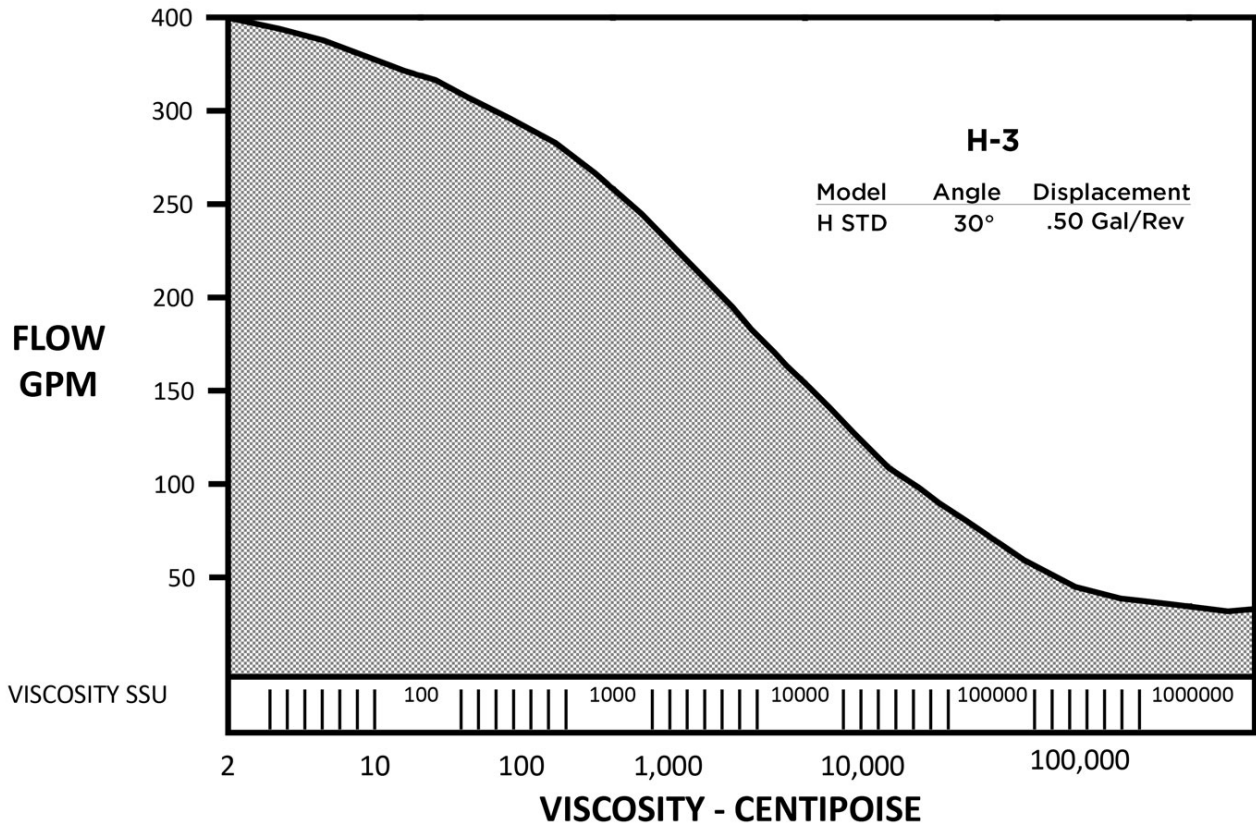
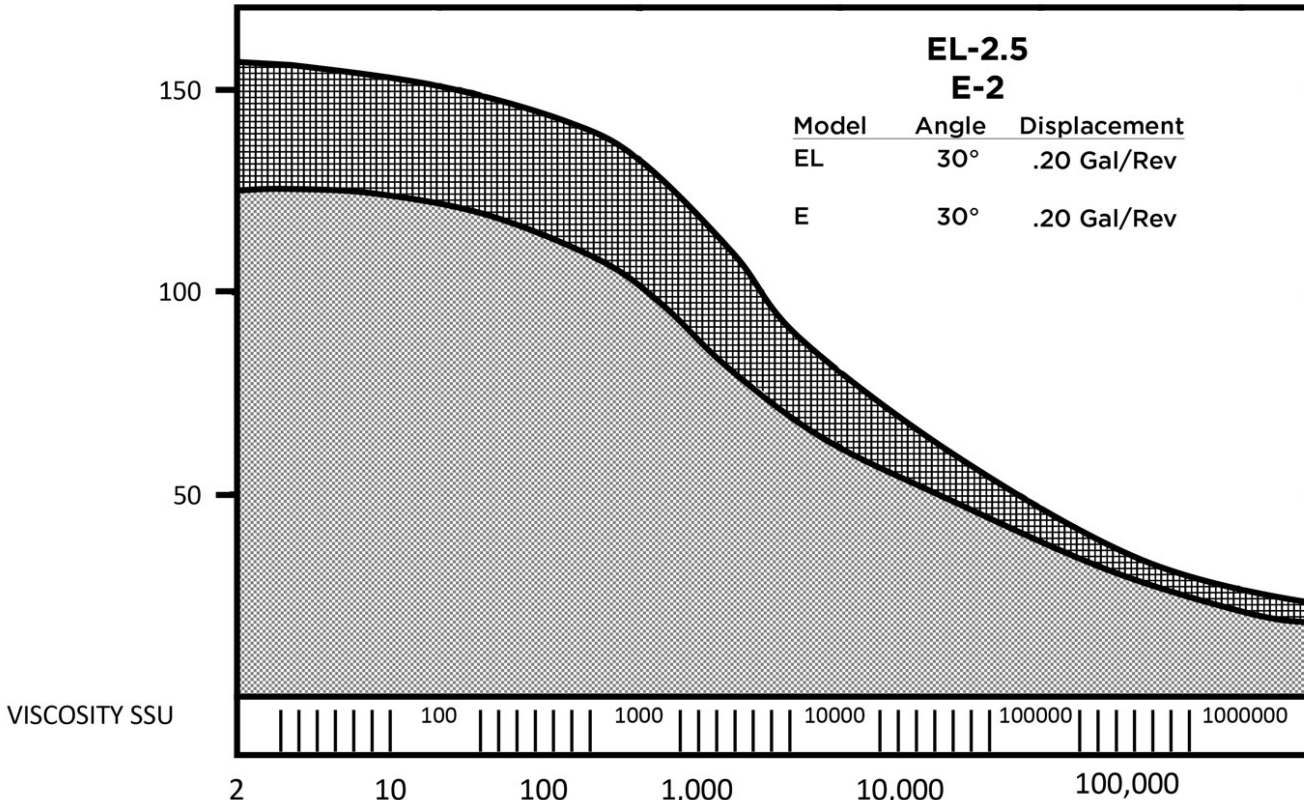

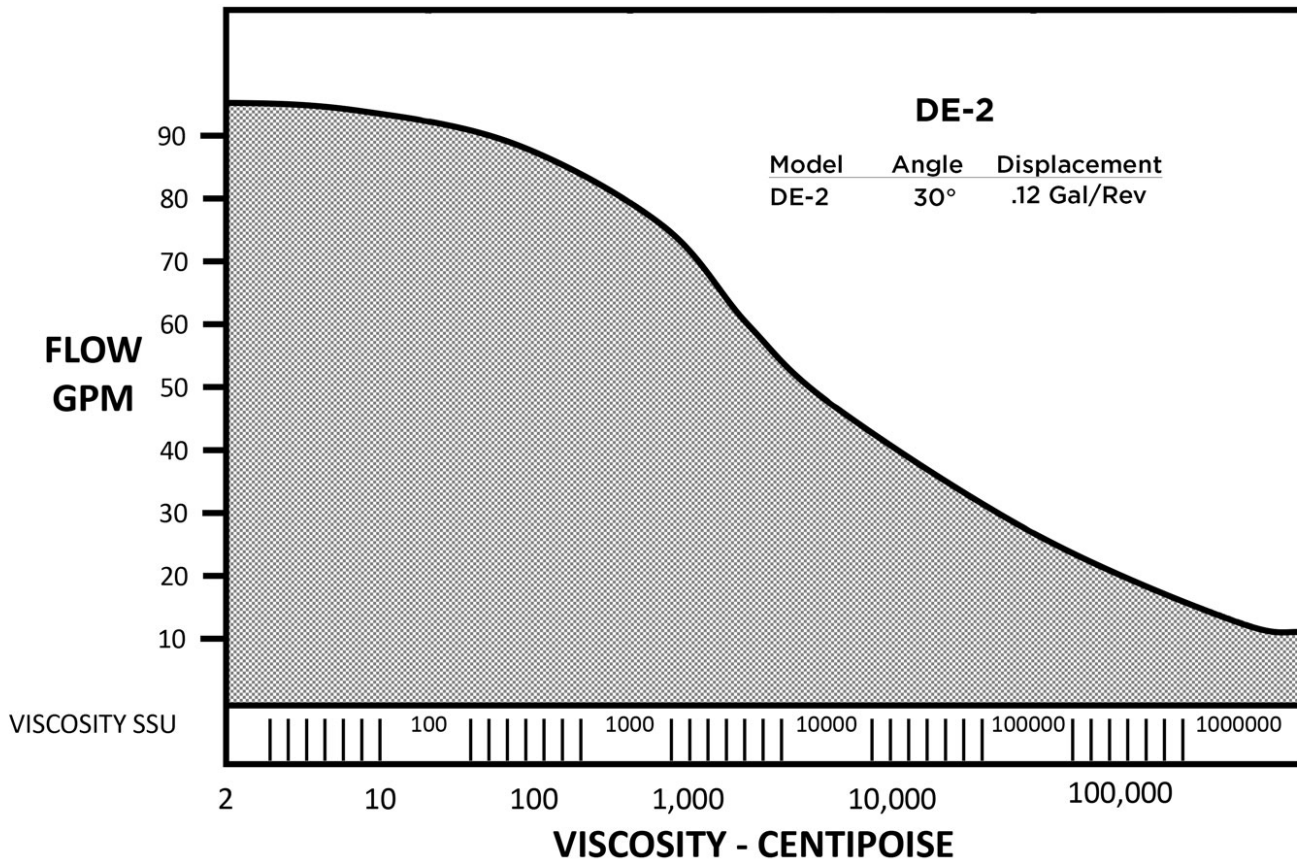
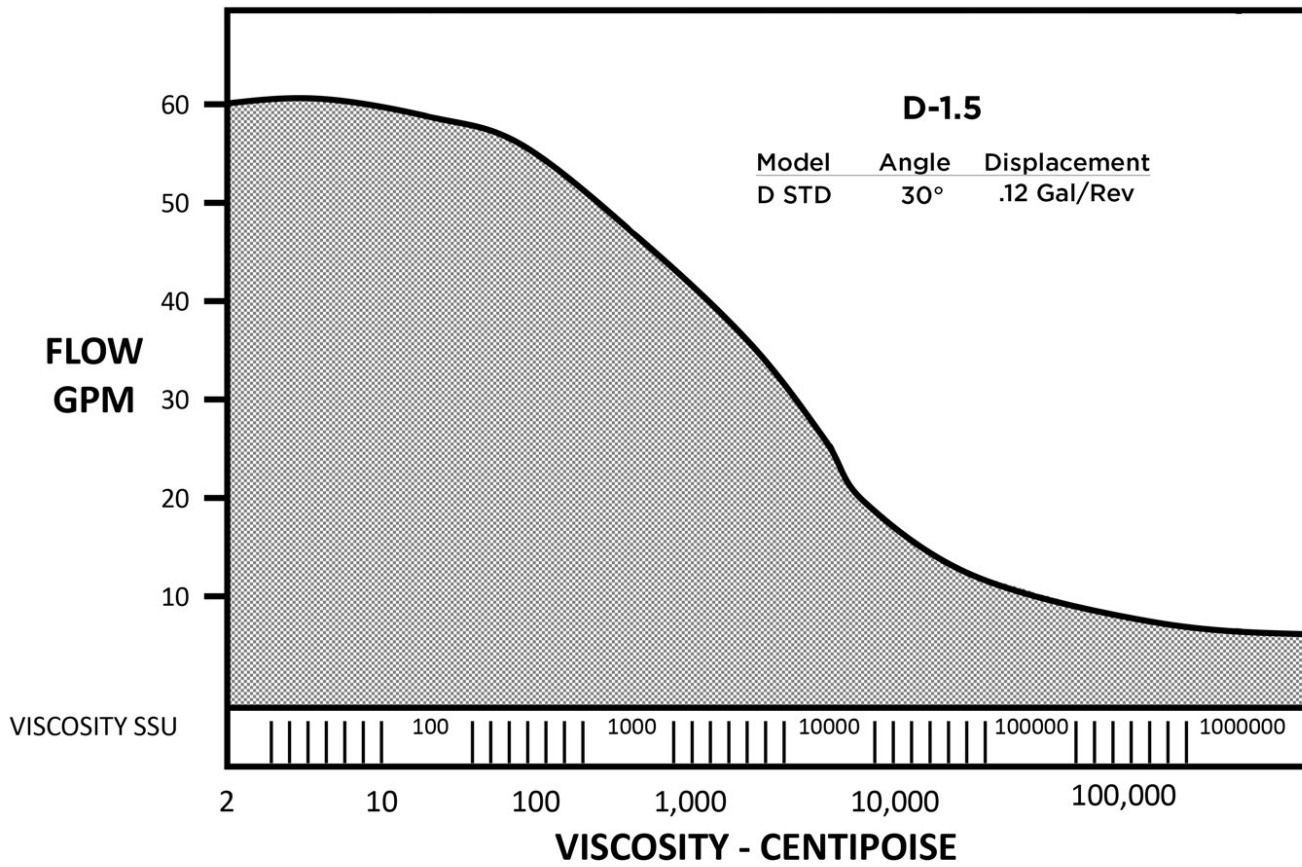

DIMENSIONS AND PERFORMANCE CHART

MODEL	SIZE NPT	MAX CAP.	MAX RPM	WEIGHT (lbs.)
D&DD	1-1/2"	60	500	63
DE & DEE	2"	90	750	65
E & EE	2"	120	600	87
EL	2-1/2"	150	750	87
H & HH	3" FLANGE	300	600	198

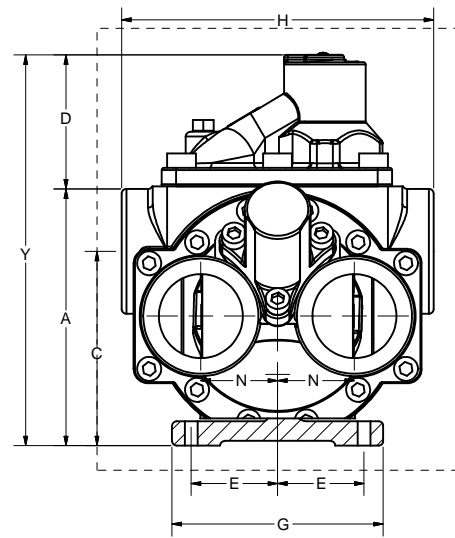
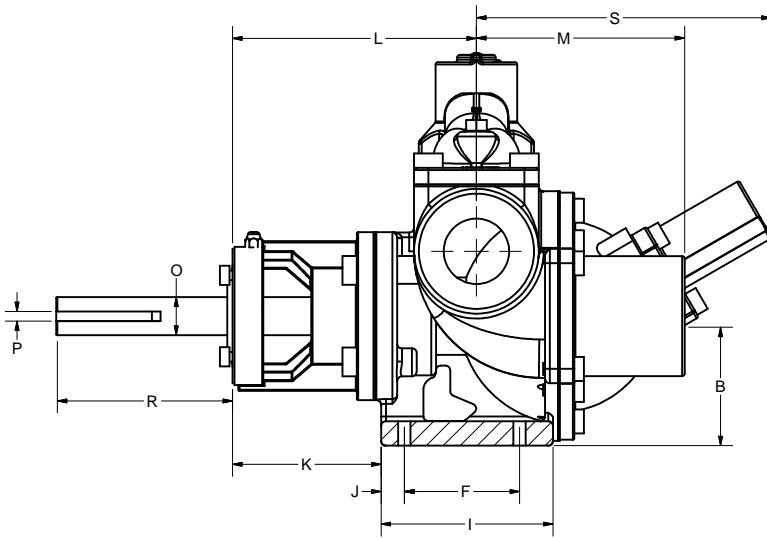

MODEL	Pipe size	A	B	C	D	E	F	G	H	I	J	K	L	M	N	O	P	R	S	X	Y	BOLTS
D	1-1/2" NPT	6.625	3.375	5.000	3.625	2.250	3.00	5.625	8.000	4.625	.75	4.375	6.750	5.375	2.000	1.000	.25	3.75	7.500	18.000	10.25	3/8"
DD	1-1/2" NPT	6.625	3.375	5.000	3.625	2.250	3.00	5.625	8.000	4.625	.75	4.375	6.750	5.375	2.000	1.000	.25	3.75	7.875	18.375	10.25	3/8"
DE	2" NPT	6.625	3.375	5.000	3.625	2.250	3.00	5.625	8.000	4.625	.75	4.375	6.750	5.375	2.000	1.000	.25	3.75	7.625	18.125	10.25	3/8"
E	2" NPT	8.625	4.375	6.875	3.625	2.434	3.50	6.125	10.250	5.125	.75	5.000	8.875	5.375	2.750	1.125	.25	4.00	8.250	21.125	12.25	1/2"
EE	2" NPT	8.625	4.375	6.875	3.625	2.434	3.50	6.125	10.250	5.125	.75	5.000	8.875	5.375	2.750	1.125	.25	4.00	8.250	21.125	12.25	1/2"
EL	2-1/2" NPT	8.625	4.375	6.875	3.625	2.434	3.50	6.125	10.250	5.125	.75	5.000	8.875	5.375	2.750	1.125	.25	4.00	8.250	21.125	12.25	1/2"
H	3" FLANGE	11.00	5.250	8.500	5.250	3.500	4.75	8.625	14.625	7.000	1.25	6.375	11.25	7.500	3.625	1.500	.25	3.75	7.625	21.125	12.25	5/8"
HH	3" FLANGE	11.00	5.250	8.500	5.250	3.500	4.75	8.625	14.625	7.000	1.25	6.375	11.25	7.500	3.625	1.500	.25	3.75	7.625	21.125	12.25	5/8"