

DIMENSIONS AND PERFORMANCE CHART

MODEL	SIZE NPT	MAX CAP.	MAX RPM	WEIGHT (lbs.)
D&DD	1-1/2"	60	500	63
DE & DEE	2"	90	750	65
E & EE	2"	120	600	87
EL	2-1/2"	150	750	87
H & HH	3" FLANGE	300	600	198

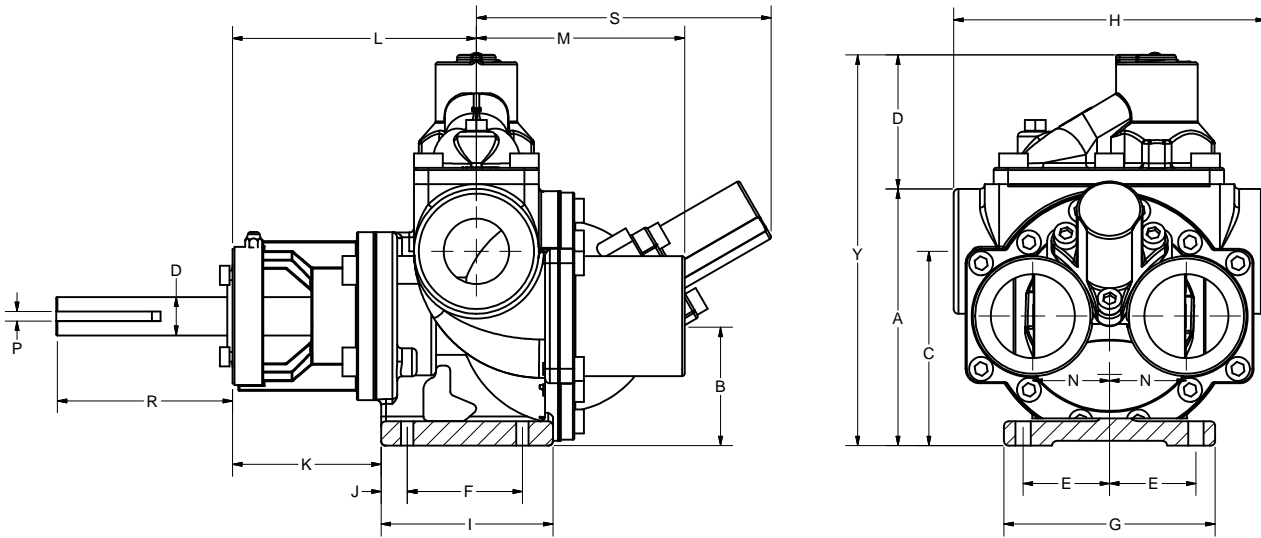

MODEL	Pipe size	A	B	C	D	E	F	G	H	I	J	K	L	M	N	O	P	R	S	X	Y	BOLTS
D	1-1/2"NPT	6.625	3.375	5.000	3.625	2.250	3.000	5.625	8.000	4.625	.750	4.375	6.750	5.375	2.000	1.000	.250	3.750	7.500	18.000	10.250	3/8"
DD	1-1/2" NPT	6.625	3.375	5.000	3.625	2.250	3.000	5.625	8.000	4.625	.750	4.375	6.750	5.375	2.000	1.000	.250	3.750	7.875	18.375	10.250	3/8"
DE	2" NPT	6.625	3.375	5.000	3.625	2.250	3.000	5.625	8.000	4.625	.750	4.375	6.750	5.375	2.000	1.000	.250	3.750	7.625	18.125	10.250	3/8"
E	2" NPT	8.625	4.375	6.875	3.625	2.434	3.500	6.125	10.250	5.125	.750	5.000	8.875	5.375	2.750	1.125	.250	4.000	8.250	21.125	12.250	1/2"
EE	2" NPT	8.625	4.375	6.875	3.625	2.434	3.500	6.125	10.250	5.125	.750	5.000	8.875	5.375	2.750	1.125	.250	4.000	8.250	21.125	12.250	1/2"
EL	2" NPT	8.625	4.375	6.875	3.625	2.434	3.500	6.125	10.250	5.125	.750	5.000	8.875	5.375	2.750	1.125	.250	4.000	8.250	21.125	12.250	1/2"
H	3" FLANGE	11.000	5.250	8.500	5.250	3.500	4.750	8.625	14.625	7.000	1.250	6.375	11.250	7.500	3.625	1.500	.375	6.250	11.500	29.000	16.250	5/8"
HH	3" FLANGE	11.000	5.250	8.500	5.250	3.500	4.750	8.625	14.625	7.000	1.250	6.375	11.250	7.500	3.625	1.500	.375	6.250	11.500	29.000	16.250	5/8"